

Kingspan HEAT PUMPS

AEROMAX
PLUS

The Ultimate Air Source Heat Pump Package



When it comes to creating efficient and cost-effective energy solutions that address today's growing environmental concerns, Kingspan Renewables leads the way.

As a division of Kingspan Group plc, a major player in the building products sector, Kingspan Renewables puts significant emphasis on energy conservation and the development of environmentally friendly solutions to generate hot water and home heating.

Climate change is now a generally accepted fact, which has increased our focus on alternative energy sources that would help to reduce not only carbon emissions (being a significant contribution to global warming), but also energy bills. One of the most efficient and cost-effective renewable energy technologies currently available for domestic and commercial applications are air source heat pumps.

Aeromax Plus Air Source Heat Pumps reflect our on-going commitment to a zero carbon lifestyle and a brighter future for us all.

Our quality product has been independently tested under the Governments **Microgeneration Certification Scheme (MCS)** and therefore qualifies for the **Renewable Heat Incentive (RHI)**, sometimes referred to as Clean Energy Cashback. For further details on **RHI** please visit www.decc.gov.uk.

Whether you need a heat pump for a new building or a refurbishment project, Kingspan can offer you the total solutions package to meet your specific needs. Kingspan is unique in its approach to providing renewable energy technologies.

Outstanding Benefits

- **Fully approved heat pump & cylinder – optimised to work together as a package**
- **Customer service team with back-up through our specialist service engineer team**
- **Training and certification available at various locations throughout the UK & Ireland**
- **Full design service for major specifiers**
- **Full availability through our distribution partners throughout the UK & Ireland**
- **Installer network**
- **Kingspan service packages available**
- **Aeromax Plus heat pumps are Microgeneration Certification Scheme approved & SAP appendix Q listed**
- **Offer cost-effective and efficient heating**
- **Easy to install**
- **2 year warranty**
- **Help in complying with Building Regulations Part L and The Code For Sustainable Homes**
- **Listed in the Harp Efficiency Database**



Accredited
Installer Network



Design Service



Training Center



Service Team



Simple
Installation



Install
with Confidence





Why A Heat Pump?

An air source heat pump collects and utilises thermal energy from the outside air to heat the home and provide domestic hot water. It does this in the same way that a fridge extracts heat from its inside.

It can extract heat from the air even when the outside temperature is as low as -20°C , it then converts this for use in a heating and hot water system.

The heat generated can be used to warm water for radiators, underfloor heating systems or provide domestic hot water in your home. The process is simple, effective and entirely renewable; something which is good for both the environment and future generations as well as our pockets.

The Aeromax Plus is an air to water based heat pump. It is a monoblock style unit, which means that the refrigerant circuit is located in the outdoor equipment only. Due to this no complicated F-Gas certification is necessary in order to install the product.

Please visit the Kingspan website or MCS listing for accredited heat pump installers.

Basic Concept of Heat Pump Technology

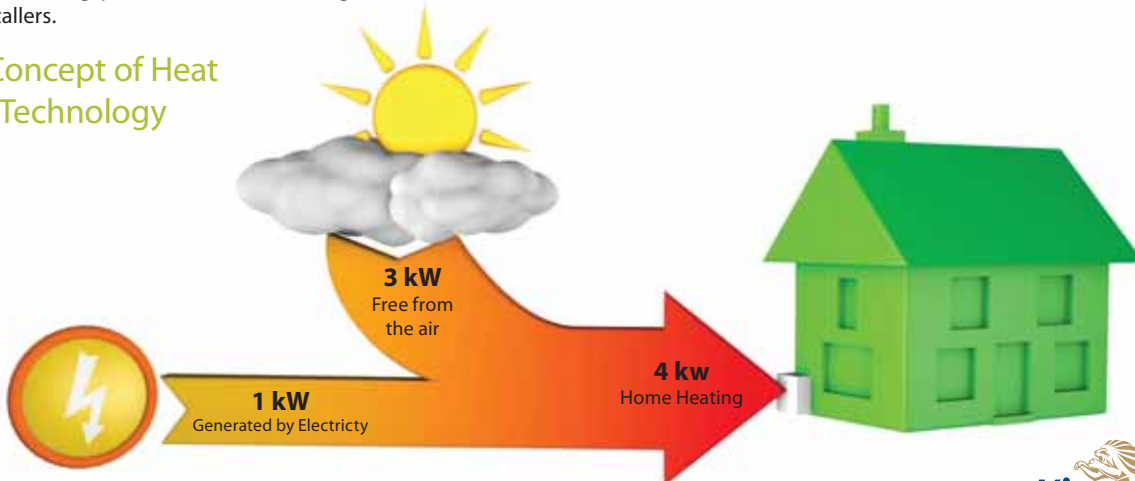

- **Reduce energy cost and CO₂ emissions by up to 50% compared to traditional systems**
- **Powerful performance with low noise**
- **No gas supply, flues or ventilation required**
- **No regular maintenance or annual safety inspections are required, unlike fossil fuel systems**
- **Perfect for refurb or new build**
- **Probably the most compact unit in today's market**
- **Safe & reliable - proven technology**
- **No need for complicated and often expensive digging or drilling, unlike ground source heat pumps**
- **Quick and simple installation**
- **Ideal for apartments and urban sites where there is very little space available**

How Do Air Source Heat Pumps Work?

Aeromax Plus Air Source Heat Pumps provide thermodynamic heating by means of a vapour compression cycle. In the same way that a fridge uses refrigerant to extract heat from the inside to keep the food cool, air source heat pump extracts heat from the outside air, and uses it to heat the home through radiators, underfloor system or provide domestic hot water. It can extract heat from the air even when the outside temperature is as low as -20°C.

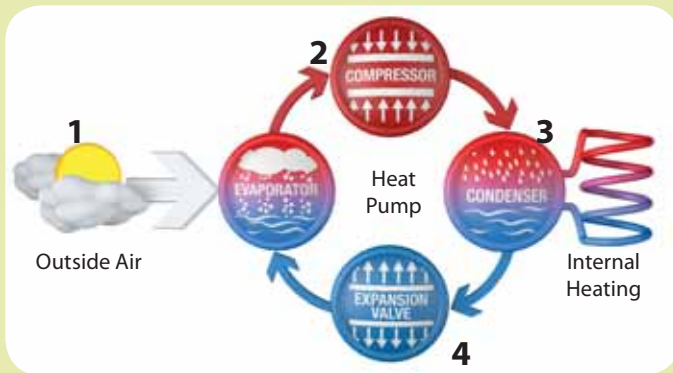

Every air source heat pump has four main parts:

1. evaporator
2. compressor
3. condenser (heat exchanger)
4. expansion device

- (1) The evaporator collects heat from the outside air, which is then drawn into the unit by the fan through the evaporator fins and expelled through the front grille. The evaporator has liquid refrigerant passing through it, which is at a considerably lower temperature than the outside air, therefore the air gives up its heat to the refrigerant, which then vaporises.
- (2) This preheated vapour now travels to the compressor where it is compressed and upgraded to a much higher temperature.
- (3) The hot vapour now enters the condenser where it is surrounded by water from the heating system. The heat is given up to the cooler water and the now cooler refrigerant returns to its former liquid state but still under high pressure from the compressor.
- (4) This high pressure is then released by passing the liquid through the expansion device and from there it returns to the evaporator and the cycle starts again.

How Much Can You Save?

An Aeromax Plus Air Source Heat Pump could save over £500 a year on your heating bills and almost 5 tonnes of carbon dioxide (CO₂) a year, however savings will vary depending on the fuel replaced and the local conditions.

Fuel Displaced	Saving per Year (£)	CO ₂ saving per year (kgCO ₂)
Gas	£70	750
Electric	£530	5,455
Oil	£160	1560
Solid	£370	5,330

Figures from www.energysavingtrust.org.uk please check the web site for latest Energy Saving Trust recommendations

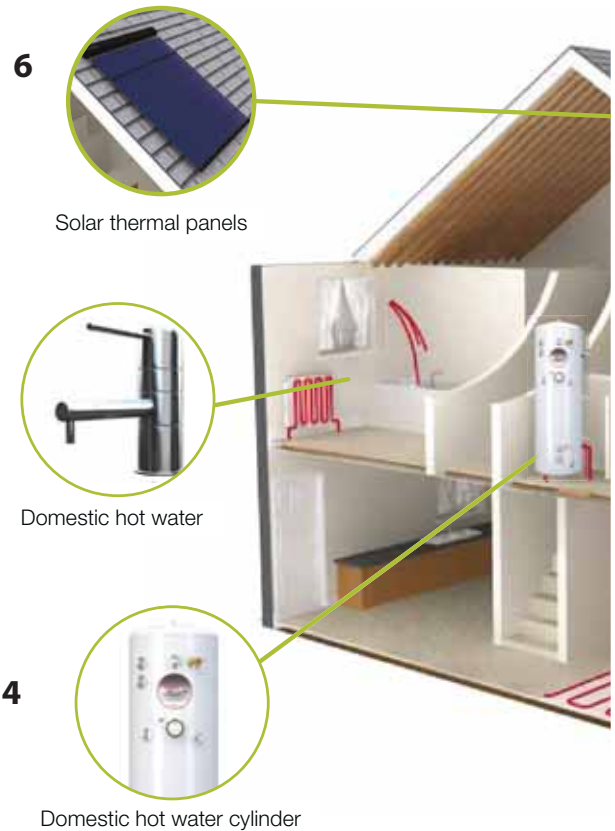

Application & Uses

1) Aeromax Plus Heat Pump

The Aeromax Plus air source heat pumps design and low noise output allows for it to be installed in a number of floor and wall mounted locations external of the property (ideally south facing).

2) Underfloor Heating

Underfloor heating uses the benefit of radiant rising heat and relatively low water flow temperatures to heat the floor surface. The heat is evenly distributed, absorbed by the structure of the building and objects in the room. This results in an efficient heating system, reducing running costs and lower carbon emissions, making this the ideal match for the Aeromax Plus Heat Pump.

3) Central Heating Radiators

The heat pump can also be used with standard radiators, sizing can mean larger radiators than with fossil fuels systems, this is due to flow temperatures of 35 to 55 degrees. Please consult a qualified energy assessor or installer to ensure optimum design

Heat Pumps and the Environment

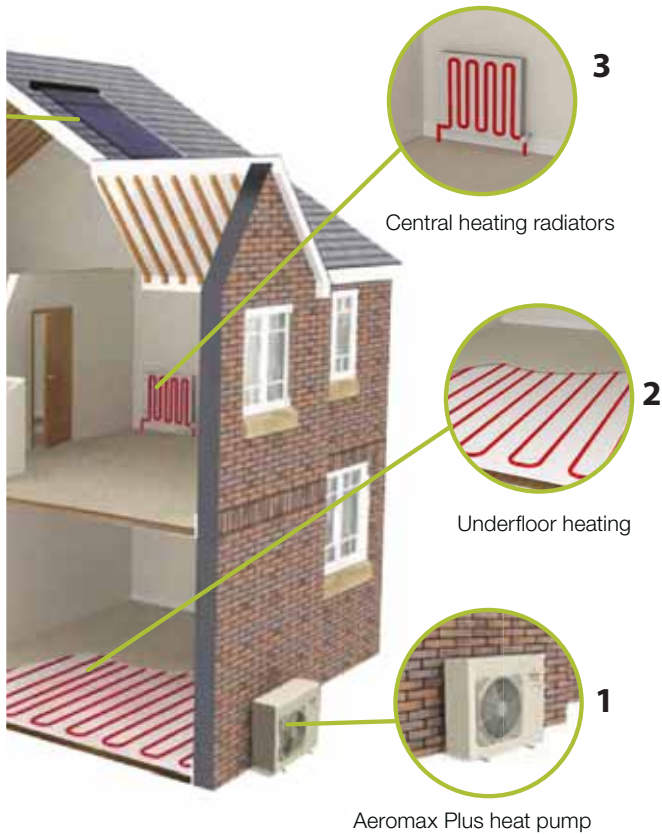

4) Domestic Hot Water Cylinder

The selection of the right hot water cylinder is key to the performance of the heat pump, we have developed a range of Copper cylinders optimized to work with the Aeromax Plus. With a larger heating coil to suit the lower flow temperatures of the heat pump.

5) Domestic Hot Water

Domestic hot water, of up to 60°C be produced using the Aeromax plus heat pump, making hot water readily available. Therefore costly back up systems such as indoor electric boilers are not required.

6) Solar Thermal Panels

Our Solar Thermal Systems are the perfect compliment to your heat pump installation and are available in various options designed to suit you individual requirements.

The 20-20-20 targets

In March 2007 the EU's leaders endorsed an integrated approach to climate and energy policy that aims to combat climate change and increase the EU's energy security while strengthening its competitiveness. They committed Europe to transforming itself into a highly energy-efficient, low carbon economy.

To kick-start this process, the EU Heads of State and Government set a series of demanding climate and energy targets to be met by 2020, known as the "20-20-20" targets. These are:

- A reduction in EU greenhouse gas emissions of at least 20% below 1990 levels
- 20% of EU energy consumption to come from renewable resources
- A 20% reduction in primary energy use compared with projected levels, to be achieved by improving energy efficiency.

The EU leaders also offered to increase the EU's emissions reduction to 30%, on condition that other major emitting countries in the developed and developing worlds commit to do their fair share under a global climate agreement. United Nations negotiations on such an agreement are ongoing.

Carbon Footprint

When fossil fuels are burned, carbon dioxide (CO₂) is released into the atmosphere contributing significantly to global warming.

Aeromax Plus heat pumps are a very simple and cost-effective way to reduce your carbon footprint and impact on the environment. They extract around 75% of usable heating energy from the environment, reducing energy consumption considerably compared with traditional heating sources.

Planning & Legislation

Legislation is already in place to ensure house builders and homeowners consider renewable energy use in their properties. Part L of the Building Regulations sets targets for carbon emissions from homes. Also the social housing sector generally has exacting standards of energy reduction via the CFSH.

With low running cost and reduced CO₂ emissions heat pumps are becoming increasingly popular with housing developers. The efficient and sustainable nature of Aeromax Plus Air Source Heat Pumps provide a solution to new build projects and indeed can free valuable internal space within the property being developed, where traditional boilers would have to be situated.

A growing number of Local Authorities include targets for use of renewable energy sources and are insisting on its provision as a condition of planning permission. Aeromax Plus Air Source Heat Pumps can help to minimise the carbon footprint of the site overall.



Advanced Technology & Performance

The Aeromax Plus uses the latest inverter driven technology which fully modulates the compressor speed to provide the exact performance to match the demanded.

Providing higher efficiency and lower running costs, combined with lower noise levels and a longer lifespan.

- **Smaller**
- **Lighter**
- **Quieter**
- **Built in weather compensation**
- **Improved performance**

Inverter Benefits - Comfort

Compressor operation (50% capacity)

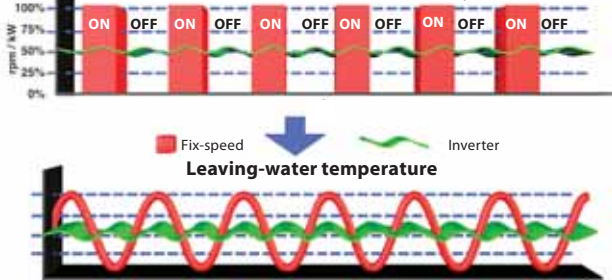

This Results Into A Stable Leaving Water Temperature

ON-OFF Compressor Operation



To climb a steep slope, the full engine power is required



On a leveled road, only a portion of the engine power is required



On a gentle descent only a small fraction of the engine power is required



Standard units adjust capacity by cycling the compressor on and off

Inverter Benefits



To climb a steep slope, the full engine power is required



On a leveled road, only a portion of the engine power is required



On a gentle descent only a small fraction of the engine power is required



Kingspan Aeromax plus Inverter adjusts capacity by correcting the compressor rpm

Condenser coil (to rear)

Removable grill for easy access to Air Management System

Compressor

Aeromax Plus Air Source Heat Pump Product Features

- Aeromax Plus Air Source Heat Pumps are available in 5 outputs: 4kW, 6kW, 8kW, 12 kW and 15kW to suit individual requirements.
- Designed specifically for use in Irish & UK housing applications in North European climates (operational to -20°C).
- Provide water temperature up to 60°C for domestic hot water applications, making hot water readily available.
- Typical comfort space heating is delivered between 35°C and 55°C.
- Designed to work efficiently with radiators or underfloor heating systems at around 400% efficiency.
- The desired temperature is quickly reached and effectively maintained without fluctuations.
- Plumbing installation has been designed to be simple, allowing easy access to all internal components and connections to both internal and external water circuits.
- Variable speed fans with an innovative patented fan blade shape ensure improved air distribution at exceptionally low noise levels.
- DC fan motor.
- Sound power level (heating) dBA 42 / 44 / 47
- Compressor operates from 20% load to 120% load, fully modulating.



Thermal Performance

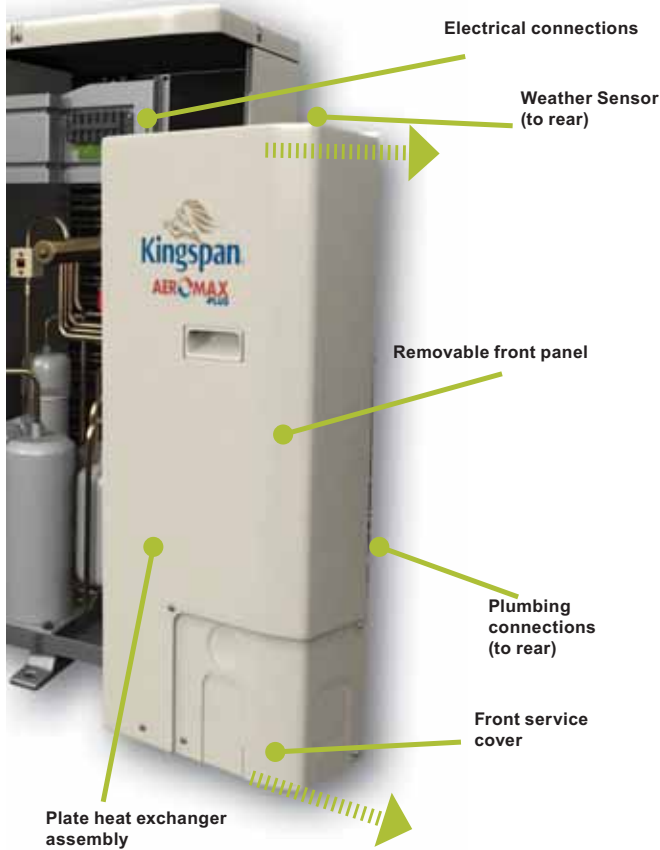

Environmental Care

- Ozone-friendly R410A refrigerant.
- Chlorine-free refrigerant of the HFC group with zero Ozone Depletion Potential.
- High-density refrigerant, therefore less refrigerant required.
- Very efficient - gives an increased energy efficiency ratio (EER).
- The components of Aeromax Plus heat pump systems are free of any hazardous substances.
- The new packaging ensures high protection during transport and handling and is 100% recyclable.



Simple Installation and Service

- Designed to allow easy access to all internal components.
- Advanced circuit design and component selection has resulted in a compact unit with an exceptionally small footprint that is easy to transport even through narrow doors.
- Reduced operating weight and a handle on the unit panels to facilitate transport.
- 3 bar pressure relief valve as standard.
- Various power cable outlet options: pre-punched holes in the cabinet panels permit cable exit on the side, front or rear.
- Specially shaped anchorage feet ensure correct and safe unit fixing to the foundation floor or wall bracket
- Condensate drain piping connection to the unit includes a leakproof pipe rubber joint.

Output Water 35°C		UNITS	4 kW	6 kW	8 kW	12 kW	15 kW
Outside Air at 7°C	Qh	KW	4.10	5.81	7.19	11.82	14.50
	COP	KW	4.06	4.22	3.92	3.98	4.06
Outside Air at 2°C	Qh	KW	3.50	4.19	5.41	8.72	10.20
	COP	KW	3.10	3.08	3.00	3.13	3.20
Outside Air at 0°C	Qh	KW	3.26	3.98	5.14	8.47	9.81
	COP	KW	3.15	2.98	2.95	3.02	3.08
Outside Air at -3°C	Qh	KW	3.01	3.67	4.73	7.80	9.06
	COP	KW	3.09	2.93	2.81	2.88	2.85

Output Water 45°C		UNITS	4 kW	6 kW	8 kW	12 kW	15 kW
Outside Air at 0°C	Qh	KW	3.17	4.02	5.11	8.03	9.80
	COP	KW	2.57	2.43	2.42	2.44	2.48
Outside Air at -3°C	Qh	KW	2.93	3.71	4.71	7.39	9.06
	COP	KW	2.42	2.31	2.34	2.32	2.36

Output Water 55°C		UNITS	4 kW	6 kW	8 kW	12 kW	15 kW
Outside Air at 0°C	Qh	KW	2.99	4.00	4.88	8.04	9.23
	COP	KW	2.04	2.16	2.20	2.08	2.08
Outside Air at -3°C	Qh	KW	2.77	3.68	4.49	7.40	8.52
	COP	KW	1.95	2.06	2.10	1.99	2.00

Operating limits	
Maximum outside temperature	30°C
Maximum leaving water temperature	60°C
Minimum outside temperature	-20°C
Minimum leaving water temperature	20°C

Operating Conditions

Large operating Envelope in both heating and hot water



LWT up to +60°C. Heating down to OAT -20°C and up to +30°C

The Kingspan Aeromax plus has one of the widest operation capacities of any unit on the market today.



The Ultimate Air Source Heat Pump Package

To optimise the entire range of benefits that Aeromax Plus heat pumps have to offer, we provide the domestic and commercial markets with a complete air source energy package that is custom-made to suit the individual needs of each application. This package is completely unique and includes the highest level of customer support from initial advice, professional planning and design, through to installation, technical and after sales support.

Aeromax & Aerocyl – The Perfect Package

Albion Aerocyl range offers Heat Pump Only cylinders and combined Heat Pump & Solar Input cylinders, which have been designed specifically for use in conjunction with a heat pump as the main or additional source of energy. Featuring a purpose-designed coil, which allows maximum heat transfer of renewable energy into the stored water, the cylinders are suitable for use with a wide range of heat pumps available in the UK & Ireland and are the perfect partners for the Aeromax Plus Air Source Heat Pumps.

- **Mains pressure hot water providing powerful showers**
- **The cylinders high flow rates are ideal for multiple bathrooms allowing baths to fill very quickly**
- **Fast reheat and high efficiency makes hot water always available**
- **Very well insulated resulting in low heat loss**
- **Economical to run**
- **Attractive white glossy finish case**
- **Aerocyl complies with the 2010 Part L Building Regulations**

Usability

The ease of use of the Aeromax Plus provides homeowners with confidence that their heating needs are being met efficiently. Indeed they will notice very little difference between the use of this renewable technology compared with traditional gas or oil boilers. The user controls provided with the systems operate in the same way to those found on a traditional domestic heating. The main difference the homeowner will notice is in the savings on their energy bills and in the reduction of their CO₂ footprint.

Combining the Best of Both Worlds

The package is suitable for both new and existing properties. In new build homes Aeromax Plus will supply the home heating and domestic hot water load. When fitting into existing dwellings the present boiler can be retained as additional heating capacity, making Aeromax the Ultimate Air Source Heat Pump Package. The use of an Aeromax Plus Air Source Heat Pump can also be combined with solar thermal water heating. In such systems normally Aeromax will provide space heating whereas domestic hot water will be heated by solar collectors, such as Thermomax vacuum tubes.



The Ultimate Air Source Heat Pump Package

Unvented Copper Hot Water Cylinder Solutions for Heat Pump and Solar Input

Aerocyl is the new unvented copper hot water storage system from Albion. Based on the company's experience in giving the trade the products they ask for, the new Aerocyl is a high quality vessel employing the best in technology. The range of Albion Aerocyl cylinders meets the needs of the builder, installer and consumer by providing fast and safe mains pressure hot water around the home in both an environmentally and pocket friendly way.

Albion Aerocyl has been designed specifically to be installed in conjunction with a heat pump only or with a solar thermal system and additional input from a heat pump. Fast flow rates, quick recovery coils and the use of an external expansion vessel to reduce maintenance are just a few of the features of Aerocyl.

At 2.1 bar operation the units meet all modern criteria for fast flow applications. Manufactured from high grade copper for excellent corrosion resistance, Aerocyl also feature energy efficient and environmentally friendly foam insulation for low heat loss and are encased in a tough, rustproofed, stove enamelled casing with white glossy finish, which can be wiped clean.

Choose Albion Aerocyl:

- Mains Pressure: Hot Water: Powerful showers
- High Flow Rates: Ideal for multiple bathrooms, baths fill very quickly
- Fast Reheat: Hot water always available
- Very Well Insulated: Low heat loss & economical to run
- Attractive White Glossy Finish Case
- Low Maintenance: No hidden costs
- 5-Year Guarantee: Peace of mind
- 5 sizes: From 150-300 litres

Immersion Heaters

All Albion Aerocyl cylinders feature electric immersion heater(s) for backup heating, when the input from the renewable energy source – heat pump and/or solar – is not sufficient to supply all hot water demand. The units are fitted with immersion heaters as follows:

Capacity (Litres)	Heat Pump Only	Heat Pump And Solar Input
150	1 x 3kW	-
180/210	1 x 3kW	1 x 3kW
250/300	2 x 3kW	1 x 3kW

Foam Insulation and Heat Loss

Albion Aerocyl cylinders have 50mm (nominal) thickness of fire retardant polyurethane foam, giving significant gains in standing heat loss values. The foam has an Ozone Depletion Potential (ODP) of 0 and a Global Warming Potential (GWP) of 1.

Capacity (Litres)	Standing Heat Loss (Kw/24Hrs)
150	1.38
180	1.63
210	1.90
250	2.21
300	2.43

Aerocyl - the perfect heat pump partner

Aeromax Plus Air Source Heat Pump can be incorporated into monovalent or bivalent heating systems in both new buildings and existing properties.

Monovalent Heating System

Where the Aeromax Plus Air Source Heat Pump is being used as the sole source of heating. The Aeromax Plus Air Source Heat Pumps would be sized to provide 100% of the heating requirement on the coldest day of the year and the entire annual domestic hot water requirement.

This is ideal for new build, well insulated properties or retrofitting into highly insulated existing dwellings with low temperature space heating requirements.

Bivalent and Integrated Heating Systems

A bivalent heating system is one in which the heating is supplied by two different types of heat sources. Aeromax Plus Air Source Heat Pumps are designed to allow integration with other traditional forms of heat sources such as gas boilers, as well as thermal applications.

Where users wish to reduce fuel bills and CO₂ emissions, the Aeromax Plus Air Source Heat Pumps can achieve this as they are ideally suited for retrofitting into existing properties allowing fuel efficiencies to be achieved whilst retaining their original boiler as back up or additional heating capacity.

In this type of application Aeromax Plus can be sized to provide a variable proportion of the annual heating requirement providing the ideal solution where lower energy consumption and carbon emissions savings can be achieved.



Monovalent Heating System

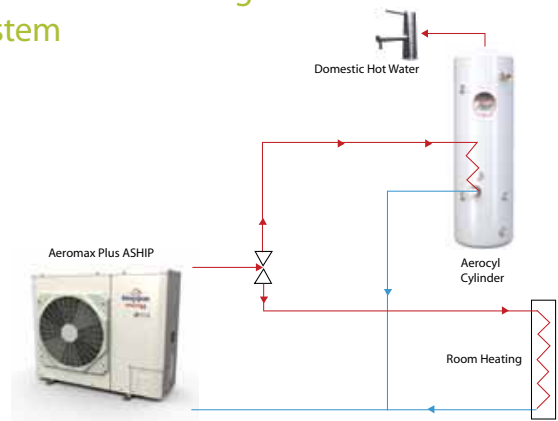

Bivalent and Integrated Heating Systems

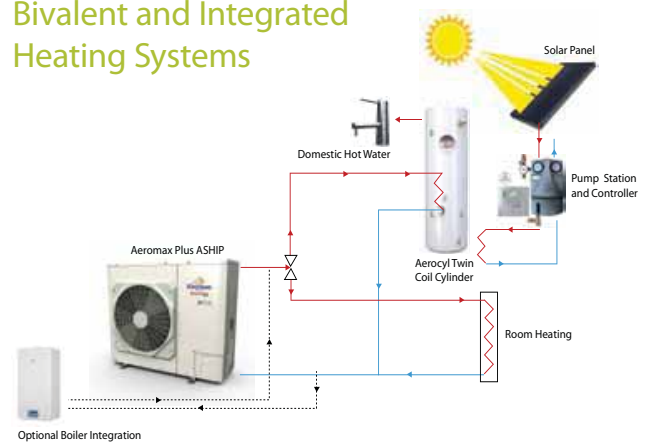

Cylinder Specifications

Heat Pump Only Cylinders

Albion Aerocyl Heat Pump Only cylinders have been specifically designed for use in conjunction with a heat pump as the main source of energy. Featuring a purpose-designed coil, which allows maximum heat transfer of renewable energy into the stored water, the cylinders are suitable for use with a wide range of heat pumps available in the UK & Ireland and are the perfect partners for the Aeromax Air Source Heat Pumps from Kingspan Renewables.

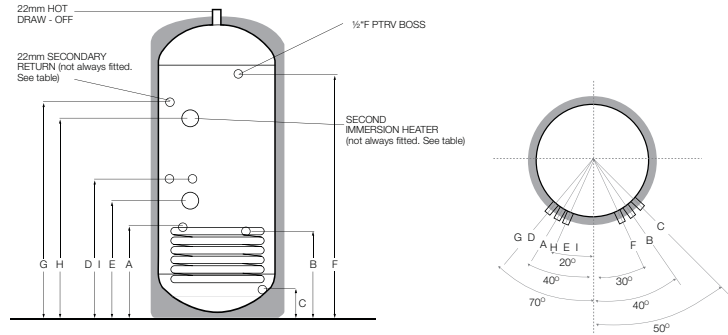

PRODUCT CODE	CAPACITY (Litres)	HEIGHT	DIAMETER	A	B	C	D	E	F	G	H	WEIGHT (Kg - EMPTY)	WEIGHT (Kg-FULL)	kW RATING*
AAU150C	150	1128	550	450	425	135	650	515	825	N/F	N/F	57	207	23.3
AAU180C	180	1322	550	450	425	135	650	515	1019	N/F	N/F	61	241	28.3
AAU210C	210	1515	550	450	425	135	650	515	1213	1100	N/F	64	274	28.1
AAU250C	250	1772	550	450	425	135	650	515	1465	1350	1195	77	327	27.4
AAU300C	300	2096	550	450	425	135	650	515	1819	1706	1515	93	393	26.7

All dimensions are in mm and are of the cased unit. N/F = not fitted
*kW rating of coil when tested in accordance with BS EN 12897

Heat Pump And Solar Input Cylinders

Albion Aerocyl Heat Pump and Solar Input cylinders have been designed specifically for use with solar thermal applications complementing the heat pump. Featuring a purpose-designed solar coil, which allows maximum heat transfer of solar energy into the stored water, the cylinders are suitable for use with a wide range of solar systems now available in the UK & Ireland and are an efficient and environmentally friendly way of providing domestic hot water. Aerocyl Heat Pump and Solar Input cylinders also offer the benefits of mains pressure hot water – powerful showers and fast filling baths.

Aerocyl Heat Pump and Solar Input cylinders are available in a range of capacities from 180 to 300 litres. They are manufactured from high grade copper and come with a 5-year guarantee on the inner container. Aerocyl Heat Pump and Solar Input cylinders are designed to accept heat input from a solar thermal system as a primary source of heat.

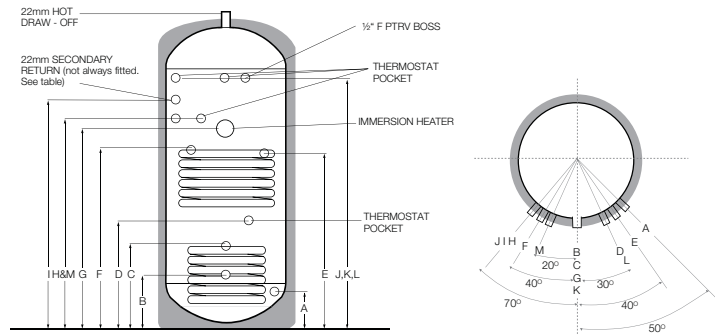

PRODUCT CODE	CAPACITY (Litres)	HEIGHT	DIAMETER	A	B	C	D	E	F	G	H	M	I	JKL	WEIGHT (Kg - EMPTY)	WEIGHT (Kg-FULL)	kW RATING* LOWER COIL	kW RATING* UPPER COIL
AAUS180C	180	1322	550	135	225	335	355	840	865	915	955	N/F	1019	65	245	22.7	34.1	
AAUS210C	210	1515	550	135	225	335	355	905	930	980	1020	1150	1213	68	278	21.5	31.9	
AAUS250C	250	1772	550	135	225	335	355	1065	1090	1140	1180	1400	1465	81	331	21.1	33.0	
AAUS300C	300	2096	550	135	225	335	355	1130	1155	1205	1245	1600	1819	97	397	20.5	33.6	

All dimensions are in mm and are of the cased unit. N/F = not fitted
*kW rating of coil when tested in accordance with BS EN 12897

Product Ordering Guide



Air Source Heat Pumps

Product Code	Description
KHP00xx	Aeromax Plus Air Source Heat Pump 4kW
KHP0038	Aeromax Plus Air Source Heat Pump 6kW
KHP0039	Aeromax Plus Air Source Heat Pump 8kW
KHP0040	Aeromax Plus Air Source Heat Pump 12kW
KHP00xx	Aeromax Plus Air Source Heat Pump 15kW

Installation Pack

The following items are required for the installation of the Aeromax PLUS Air Source Heat Pump

Product Code	Description
KHP0029	4kW, 6kW & 8kW Installation Pack
KHP0030	12kW & 15kW Installation Pack



2 x 750mm flexible hoses including 90° elbow, pre-insulated



1 x system filter



W Plan diverter valve



Flush & Fill Ports



Anti vibration pads



Diagnostic Indicator



Flow Setter



Programable room stat



7 day hot water programmer



2 x Full bore isolating valve with lever arm

Product Code	Description
KHP0023	1 x 25 litre system antifreeze inhibitor - Clear



1 x 25 litre clear - system antifreeze inhibitor

Optional Installation Accessories

To assist in the installation we offer a wide range of accessories.



Filling station



Weather sensor

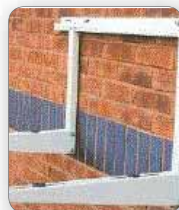

Wall mounting bracket & condensate tray.



Protective cage



Advanced programmable controller



Anti vibration foot

Product Ordering Guide

Each pack consists of Aeromax Plus heat Pump, installation pack and antifreeze. Then simply add the Aerocyl cylinder for the complete package solution.

4 kW – Heat Pump Pack

KHP0041	Aeromax Plus Air Source Heat Pump 6kW
KHP0029	Installation Pack
KHP0023	1 x 25 litre system antifreeze inhibitor - clear

Now just add your Aerocyl cylinder from the list below

6 kW – Heat Pump Pack

KHP0038	Aeromax Plus Air Source Heat Pump 6kW
KHP0029	Installation Pack
KHP0023	1 x 25 litre system antifreeze inhibitor - clear

Now just add your Aerocyl cylinder from the list below

8 kW – Heat Pump Pack

KHP0039	Aeromax PLUS Air Source Heat Pump 8kW
KHP0029	Installation Pack
KHP0023	1 x 25 litre system antifreeze inhibitor - clear

Now just add your Aerocyl cylinder from the list below

12 kW – Heat Pump Pack

KHP0040	Aeromax PLUS Air Source Heat Pump 12kW
KHP0030	Installation Pack
KHP0023	1 x 25 litre system antifreeze inhibitor - clear

Now just add your Aerocyl cylinder from the list below

15 kW – Heat Pump Pack

KHP0042	Aeromax PLUS Air Source Heat Pump 12kW
KHP00xx	Installation Pack
KHP0023	1 x 25 litre system antifreeze inhibitor - clear

Now just add your Aerocyl cylinder from the list below

Aerocyl heat Pump Cylinders

Aerocyl Unvented Copper Renewable Cylinders for Heat Pump and Solar Input

Code	Description	Capacity (Ltrs)
AAU150C	Single Coil (Heat Pump Input only)	150
AAU180C	Single Coil - Heat Pump Input only	180
AAU210C	Single Coil - Heat Pump Input only	210
AAU250C	Single Coil - Heat Pump Input only	250
AAU300C	Single Coil - Heat Pump Input only	300
AAUS180C	Twin Coil (Heat Pump and Solar Input)	180
AAUS210C	Twin Coil - Heat Pump and Solar Input	210
AAUS250C	Twin Coil - Heat Pump and Solar Input	250
AAUS300C	Twin Coil - Heat Pump and Solar Input	300



Technical Specifications

Aeromax Plus	Model	4 kW	6 kW	8 kW	12 kW	15 kW
	Codel	KHP0041	KHP0038	KHP0039	KHP0040	KHP0042
Data at Eurovent LCP/A/CHF conditions						
Nominal heating capacity	kW	4.1	5.8	7.2	11.9	14.5
Power input	kW	1.01	1.37	1.82	3.01	3.57
COP	kW/kW	4.06	4.24	3.95	3.94	4.06
Eurovent class, heating		A	A	B	B	A
Data at Eurovent LCP/A/AC conditions**						
Nominal heating capacity	kW	3.9	5.8	7.4	12.9	14
Power input	kW	1.22	1.90	2.32	4.26	4.36
COP	kW/kW	3.2	3.06	3.18	3.03	3.21
Eurovent class, heating		A	B	B	B	B
Sound levels						
Sound power level, heating‡	dB(A)	62	62	64	67	68
Sound pressure level, heating‡	dB(A)	42	42	44	47	48
Electrical data						
Power supply	V-ph-Hz	230/240V /- 1N /50Hz				
Voltage range	V	207 / 253				
Full load current	A	7.2	11	14	22.8	20
Fuse rating	A	10	15	15	25	25
Main power cable section	mm2	2.5	2.5	2.5	2.5	2.5
Water pressure drop,						
	kPa (CHF)	16	9.5	14.5	26	33
Fan Power Input	(kW) (CHF)	0.09	0.09	0.099	0.191	0.19
Fan Speed	(RPM) (CHF)	200-600	200-600	200-680	250 - 730	200-820
Current Input	(A) (CHF)	0.65	0.65	0.85	1.63	1.18
Nominal Flow Rate	(l/min)	12	16.8	19.8	34.8	41.4
Minimum Flow Rate (to operate flow switch)	(l/min)	8	8	8	8	8

* Standard Eurovent LCP/A/CHF conditions in heating mode: water heat exchanger entering/leaving water temp. 30°C/35°C, outside air temp. 7°C db/6°C wb.
 *** Ecolabel LCP/A/CHF conditions in heating mode: water heat exchanger entering/leaving water temp. 30°C/35°C, outside air temp. 2°C db/1°C wb. Performances are in accordance with EN 14511
 ‡ Based on the following conditions: entering/leaving water temperature 35°C/30°C, outside air temperature 7°C.
 †† Based on the following conditions: entering/leaving water temperature 12°C/7°C, outside air temperature 35°C.
 Note: The sound pressure level is measured in a hemispheric field at 4 m distance from the unit.

4 / 6 / 8 kW

12 / 15 kW

Model	Dimensions and Weights									
	A	B	C	D	E	F	G	H	L	kg
4 kW	908	821	326	350	87	356	466	40	60	56
6 kW	908	821	326	350	87	356	466	40	60	58
8 kW	908	821	326	350	87	356	466	40	60	68
12 kW	908	1363	326	350	174	640	750	44	69	99
15 kW	908	1363	326	350	174	640	750	44	69	124

Dimensions and Weights

The Complete Package From Kingspan

We believe in providing our customers with a one-stop-shop for complete package solutions; from market-leading products, free initial advice, through to bespoke design, installation, final commissioning and technical support. allowing you to purchase with confidence. As a company committed to environmentally friendly energy solutions, we want to do everything we can to give homeowners confidence both in installing renewable energy

Coates Environmental & Renewable Design Partnership

Professional design, planning and sizing is an important and inseparable factor when installing heat pumps into new properties or into existing dwellings, where the central heating and domestic hot water systems, already installed, are to work with the Aeromax Plus Air Source Heat Pump.

That is why we don't confine our offer to simply selling the heat pump, but provide a complete service package, from initial advice and design, to training and technical support, making installation straightforward and stress-free.

Renewable Energy Training Centre

Sustainable energy systems have become an important area for the building services industry. Understanding how to provide these sources, systems and applications is seen as key in meeting the future needs of both commercial and domestic heating.

We offer a range of courses that have been specifically designed to provide experienced heating, plumbing, installation and building professionals with a real understanding of the potential for renewable energy sources, installation and their application. Our nationwide training courses offer an industry standard qualification which will help towards MCS accreditation.

Install with Confidence.

With growing pressure to source alternative energy, reduce carbon emissions and cut energy bills, an increasing number of homeowners in the UK & Ireland are turning to renewable energy sources. To ensure that they receive the highest standards of conduct, workmanship and customer service, Kingspan has introduced a national network of accredited installers. To bring peace of mind to homeowners looking to install renewable hot water systems.

To be accepted for the scheme, companies have to meet standards set out in a Code of Practice agreed by Kingspan Solar. These include holding fully compliant British Plumbing Employers Council (BPEC or FETAC) qualifications, demonstrating their ability to do the job to the highest standard and ensuring excellent customer service before, during and after the system is installed.

Field service team

Our in-house field service team means that customers can rest assured that one-on-one support is available right across the country. The service team of highly qualified field-based engineers will bolster existing in-house support services with technical field support across the UK & Ireland .

Fully trained to service the entire portfolio of Kingspan Renewable's products, the engineers will provide full technical back-up as well as being on hand to oversee installations and provide on-site training for installers.



cdp Coates Environmental & Renewable Design Partnership



AeroServ **SolarServ** **AquaServ**

Guarantee

The Aeromax Plus Heat Pump Package is designed for a long operational life. All components of the package carry a guarantee against faulty materials or manufacture:

- 2 years on Aeromax Plus Air Source Heat Pump (1st year for parts and labour, 2nd year for parts only).
- 5 years on the Albion Aerocyl Unvented Copper cylinder.
- 2 years on the parts associated with the cylinder.

For the guarantee to be valid it is necessary that the system has been correctly installed in line with Installation Manual, Operating Instructions and all the relevant standards, regulations and codes of practice in force at the time.



Kingspan Renewables have a policy of continuous product development and may introduce product modifications from time to time. As a consequence details given in this brochure are subject to alteration without notice.



Kingspan Renewables Limited

180 Gilford Road, Portadown, Co. Armagh, Northern Ireland,
BT63 5LF, United Kingdom.

Tel: +44 (0) 28 3836 4500 Fax: +44 (0) 28 3836 4501

E-mail: info@kingspansolar.com

www.kingspansolar.com

Kingspan Renewables

Tadman Street, Wakefield, WF1 5QU.

Tel: +44 (0) 1924 376 026 Fax: +44 (0) 1924 385 015
Freephone (GB only) Tel: 0845 812 0007 Fax: 0845 812 0008

E-mail: sales@kingspansolar.co.uk

www.kingspansolar.co.uk